

KC2700 Series

EMC Circular Backshell with reworkable band clamp

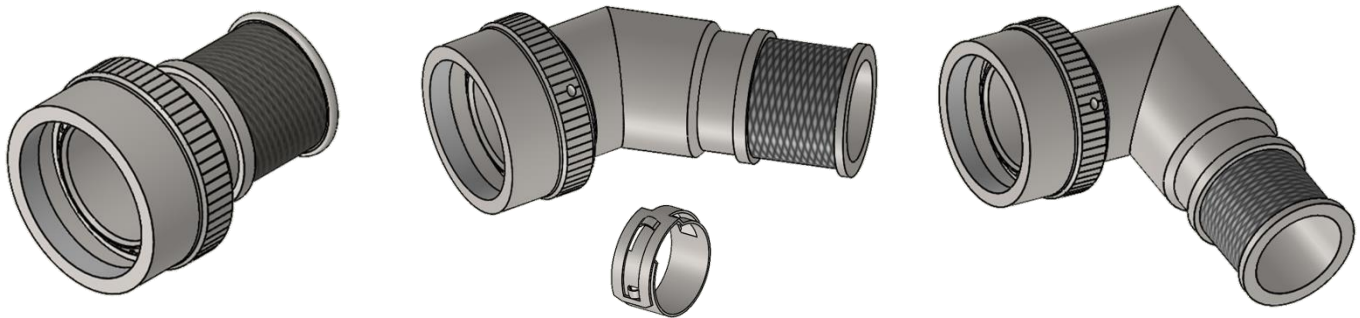

- Light weight and compact backshell suitable for all standard circular connectors
- High levels of EMC and Environmental performance
- Overall screening by reworkable band clamp
- Rapid assembly with no special tools required and the system is easily reworked
- Teeth on backshell body mesh with connector teeth for positive lock
- Blind teeth for increased EMC screening with internal taper for enhanced environmental sealing with the connector
- Additional environmental sealing of cable system by heat shrink boot
- Overall environmental seal with heat shrink boot is equal to or higher than the IP rating of the connector

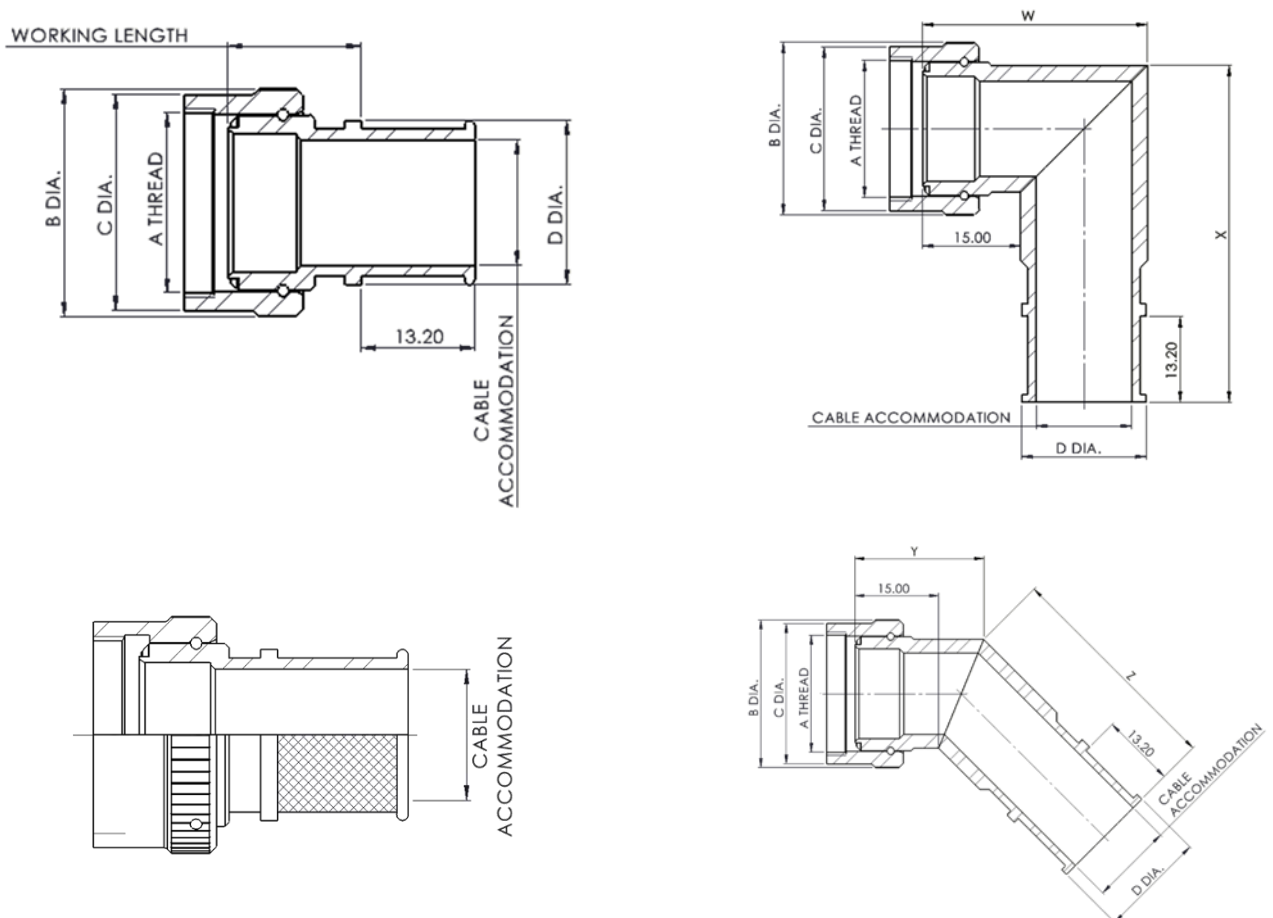

KEC LIMITED

Orpheus House, Calleva Park, Aldermaston, Reading, Berkshire RG7 8TA England

www.kec.co.uk

Tel: +44 (0)118 981 1571 email: sales@kec.co.uk

EXAMPLE PART NUMBER

KC2701 - 32 - 25 W 1 - 25 -XXX

Material - Table 1

Connector Series - Table 3

Shell Size - Table 2

Finish - Table 5

Working Length - Note 2

Cable Entry - Table 4

Mod Code - Note 5

TABLE 2 (See Notes 1 and 3)

SHELL SIZE	A THREAD 22/26/38 SERIES	A THREAD 28 SERIES	A THREAD 32 SERIES	B DIA MAX	C DIA MAX	W DIM MAX	X DIM MAX	Y DIM MAX	Z DIM MAX
08/09	7/16" - 28 UNEF	1/2" - 20 UNF	M12 x 1.00-6H	18.00	15.95	27.00	34.00	20.50	27.00
10/11	9/16" - 24 UNEF	5/8" - 24 UNEF	M15 x 1.00-6H	21.20	18.95	29.00	35.50	21.00	28.00
12/13	11/16" - 24 UNEF	3/4" - 20 UNEF	M18 x 1.00-6H	23.10	21.65	33.00	40.00	23.00	29.50
14/15	13/16" - 20 UNEF	7/8" - 20 UNEF	M22 x 1.00-6H	26.60	25.40	35.00	41.50	23.50	30.50
16/17	15/16" - 20 UNEF	1.000" - 20 UNEF	M25 x 1.00-6H	29.10	28.15	38.00	44.50	25.00	31.75
18/19	1 1/16" - 18 UNEF	1 1/16" - 18 UNEF	M28 x 1.00-6H	32.40	30.40	40.00	46.50	26.00	32.50
20/21	1 3/16" - 18 UNEF	1 3/16" - 18 UNEF	M31 x 1.00-6H	34.60	33.95	43.50	50.00	27.00	34.00
22/23	1 5/16" - 18 UNEF	1 5/16" - 18 UNEF	M34 x 1.00-6H	38.10	36.70	46.50	53.50	28.50	35.50
24/25	1 7/16" - 18 UNEF	1 7/16" - 18 UNEF	M37 x 1.00-6H	42.90	40.65	49.00	55.50	29.50	36.50

TABLE 3 (See Note 3)

SERIES CODE STRAIGHT	SERIES CODE 45° ANGLE	SERIES CODE 90° ANGLE	CONNECTOR TYPE (TYPICAL. See Note 4)	SHELL SIZE
22	42	82	MIL-C-26482 SERIES 1, PAT 105, 608, 603	08-24
26	46	86	MIL-C-38999 SERIES 1 & 2, PAT 614 & 616, PAN 6433-1	08-24
28	48	88	MIL-C-83723 SERIES 1 & 3, MIL-C-26482 SERIES 2 PAT 602 & PAN 6432-1 & 4	08-24
32	52	92	MIL-C-38999 SERIES III & IV, METRIC THREADS (EN3645)	09-25
38	58	98	PAN 6433-2, LN29729	08-24

TABLE 1

MATERIAL CODE

01	ALUMINIUM
02	STAINLESS STEEL
03	ALI BRONZE

TABLE 4

ENTRY CODE	CABLE ACCOMODATION	D DIA
08/09	7.5	12.3
10/11	9.3	13.1
12/13	12.7	17.4
14/15	14.4	19.2
16/17	17.8	21.5
18/19	19.6	23.7
20/21	24.1	27.9
22/23	27.0	30.9
24/25	29.2	33.5

TABLE 5

FINISH CODE

G	BLACK ZINC NICKEL
J	ELECTROLESS NICKEL
W	CADMIUM + OLIVE DRAB
Z	ZINC COBALT + OLIVE DRAB

NOTES:

- The W,X,Y,Z, lengths given on the data sheet are based on shell size and cable entry size being equal, i.e. 14/14, 21/21. If there is a step up or a step down required in the finished part number, a small amount of additional length is required to allow for the transition.
- Working Length in 12.7mm (0.5in) increments. for example, working length 4 = 50.8mm (2in). KC2700 minimum working length is 1. (straight backshells only – omit on angled versions). Angled dimensions are shown as W X Y and Z.
- A thread sizes shown in TABLE 2 for STRAIGHT SERIES CODE backshells also apply to equivalent 45° ANGLE and 90° ANGLE SERIES CODES.
- The above information is typical and many other connector type options & variations are available. For full dimensional details and other options, consult factory.
- Used for modification to standard parts.

KEC LIMITED

Orpheus House, Calleva Park, Aldermaston, Reading, Berkshire RG7 8TA England

www.kec.co.uk

Tel: +44 (0)118 981 1571 email: sales@kec.co.uk